

# Large Portable Popup Bar

PBFL301

The Portable Popup Bar is a portable, wheeled sampling and serving station perfect for any event. The pre-assembled aluminium frame comes together by unfolding the legs, and inserting the interior shelf panels. Fully-customized graphics and printed top will win visitors over as you provide an effortless serving experience.



We are continually improving and modifying our product range and reserve the right to vary the specifications without prior notice. All dimensions and weights quoted are approximate and we accept no responsibility for variance. E&OE. See Graphic Templates for graphic bleed specifications.

## features and benefits:

- Portable, pre-assembled aluminium frame
- Zipper-enclosed storage space
- Printable graphics available
- Locking wheel casters
- Kit includes frame, four shelves and a carry bag
- 1 year hardware warranty against manufacturer defects

## dimensions:

Hardware	Shipping
<p>Assembled unit: 40.13"w x 36.5"h x 20.06"d 1020mm(w) x 928mm(h) x 510mm(d)</p> <p>Approximate weight: 26 lbs / 12 kg</p>	<p>Packing case(s): 1 Carry bag</p> <p>Shipping dimensions: 41"l x 21"h x 7"d 1042mm(l) x 534mm(h) x 178mm(d)</p> <p>Approximate total shipping weight: 30 lbs / 14 kg</p>
Graphic	additional information:
<p>Refer to related graphic template for more information.</p>	<p>Graphic material: Oxford</p> <p>Shelves are shipped inside the Popup Bar on the bottom level.</p> <p>When included in a larger kit, a different packaging solution will be listed to accommodate all contents of the kit. Individual packaging no longer provided.</p>



2010 Hancock Street  
San Diego, CA 92110  
800.697.4670  
[sales@beautifuldisplays.com](mailto:sales@beautifuldisplays.com)

# Included In Your Kit

Tools, Components, & Connectors

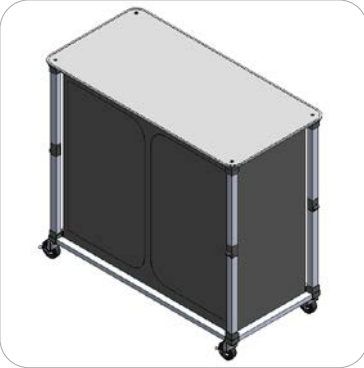

Large Portable Popup Bar x1



SHELF x4

# Kit Assembly

## Step by Step

### Step 1.

Unfold and lock legs.



### Step 2.

Unzip and insert shel ves.

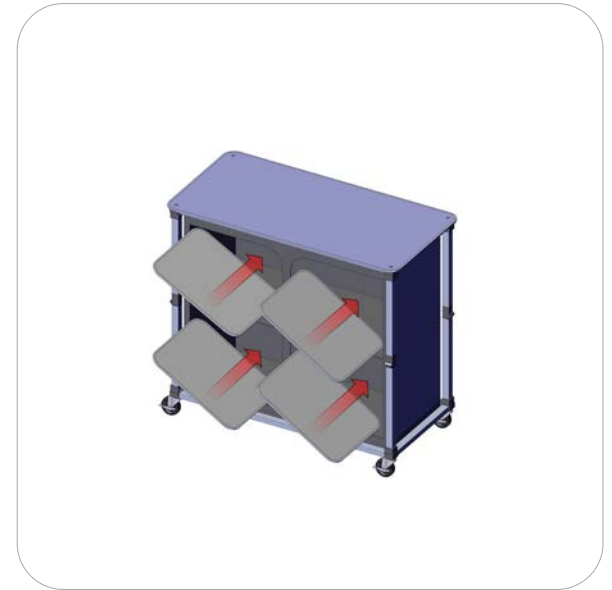
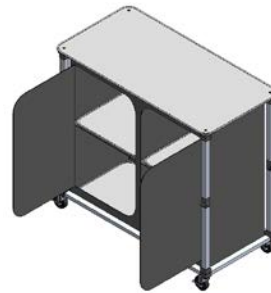

### Step 3.

Zip door to close or roll up velcro to stay open.

If graphics have been purchased move on to step 4, otherwise Set-up is complete.

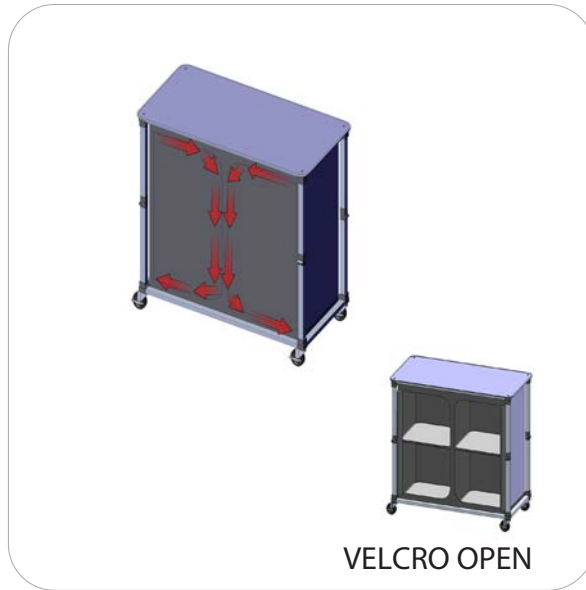

### Step 4.

Apply graphics by pressing the sides of the graphics onto the counter, making sure the velcro bands are aligned with one another.

Set-up is complete

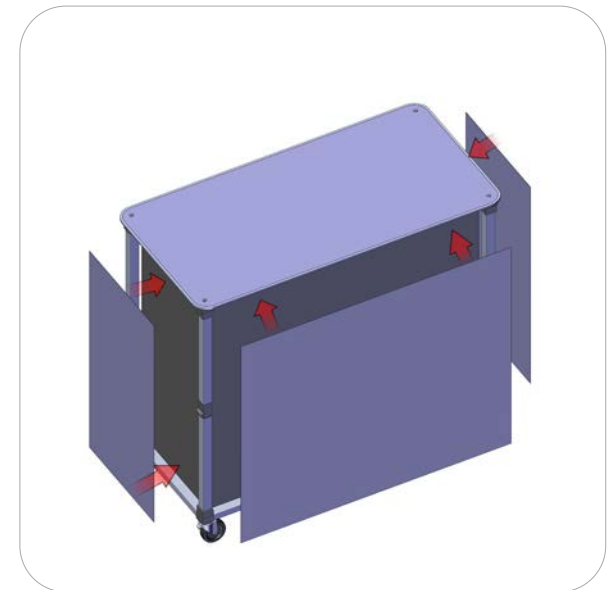
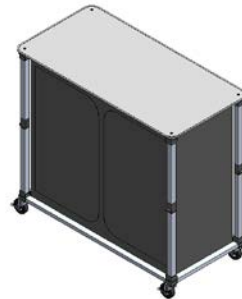

# PopUp Bar Large Header

PBFL301-B-HDR

The large portable Popup Bar header is an accessory that easily attaches to the large Popup Bar counter top. The aluminum tube frame simply screws into the counter top. A stretchy printed fabric graphic slips over the top of the frame for branding and messaging.



## features and benefits:

- Lightweight tube frame
- Fabric graphics slip over frame
- Connects to counter top
- Can be recycled
- One year limited hardware warranty against manufacturer defects

## dimensions:

Hardware	Graphic
<p>Assembled unit: 38.23"w x 59.52"h x 1.18"d 972mm(w) x 1512mm(h) x 30mm(d)</p> <p>Approximate weight (Hardware only): 3 lbs / 2 kg</p>	<p>Refer to related graphic template for more information.</p>
Shipping	additional information:
<p>Packing case(s): 1 Box(es)</p> <p>Shipping dimensions: 48"l x 11"h x 4"d 1220mm(l) x 280mm(h) x 102mm(d)</p> <p>Approximate total shipping weight: 4 lbs / 2 kg</p>	<p>Graphic material: Dye-sublimation zipper pillowcase fabric</p>

We are continually improving and modifying our product range and reserve the right to vary the specifications without prior notice. All dimensions and weights quoted are approximate and we accept no responsibility for variance. E&OE. See Graphic Templates for graphic bleed specifications.



2010 Hancock Street  
San Diego, CA 92110  
800.697.4670  
[sales@beautifuldisplays.com](mailto:sales@beautifuldisplays.com)

# Included In Your Kit

Tools, Components, & Connectors



PBFL301-B-HDR-T1 x2



PBFL301-B-HDR-T x1

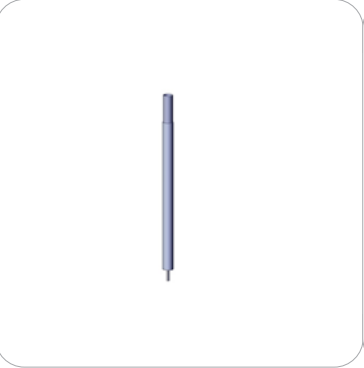

PBFL301-B-HDR-T6 x2



TC-30-90 x2

Graphics

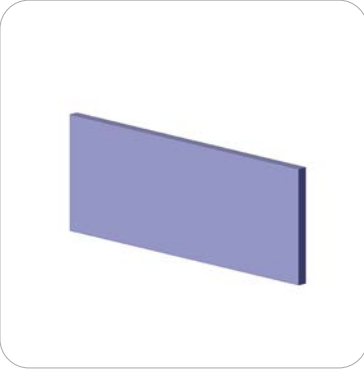

PBFL301-B-HDR-G x1

# Exploded Diagram

PBFL301-B-HDR

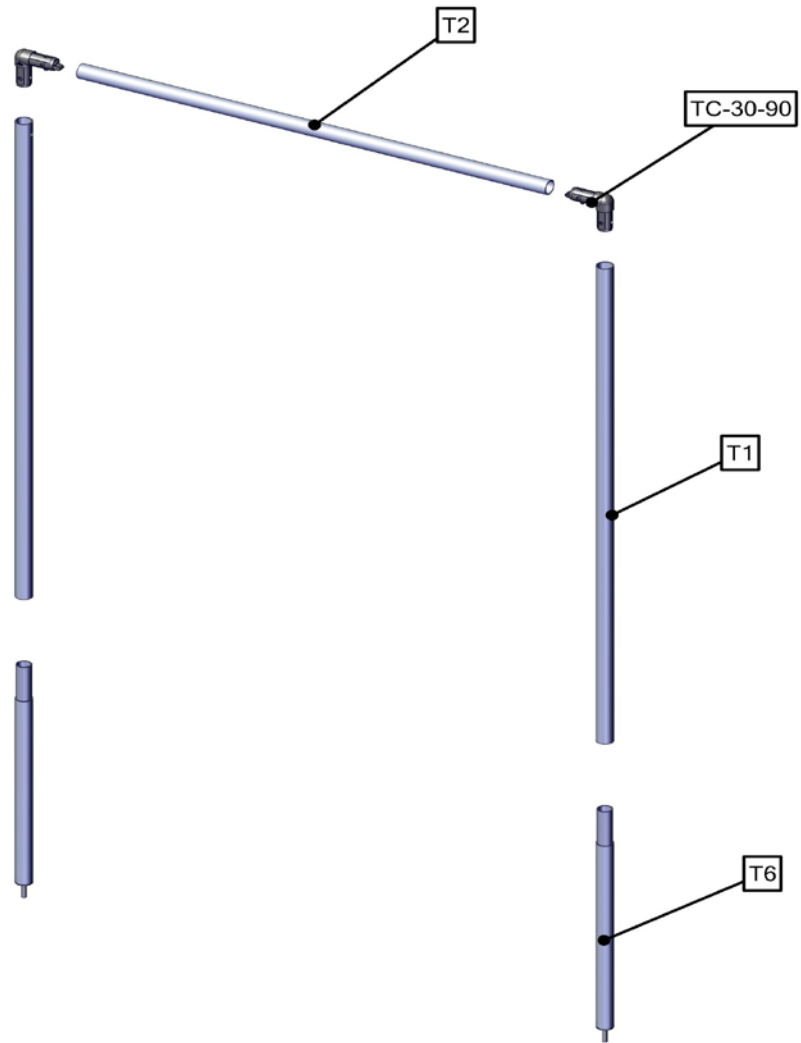

# Labeling Diagram

PBFL301-B-HDR

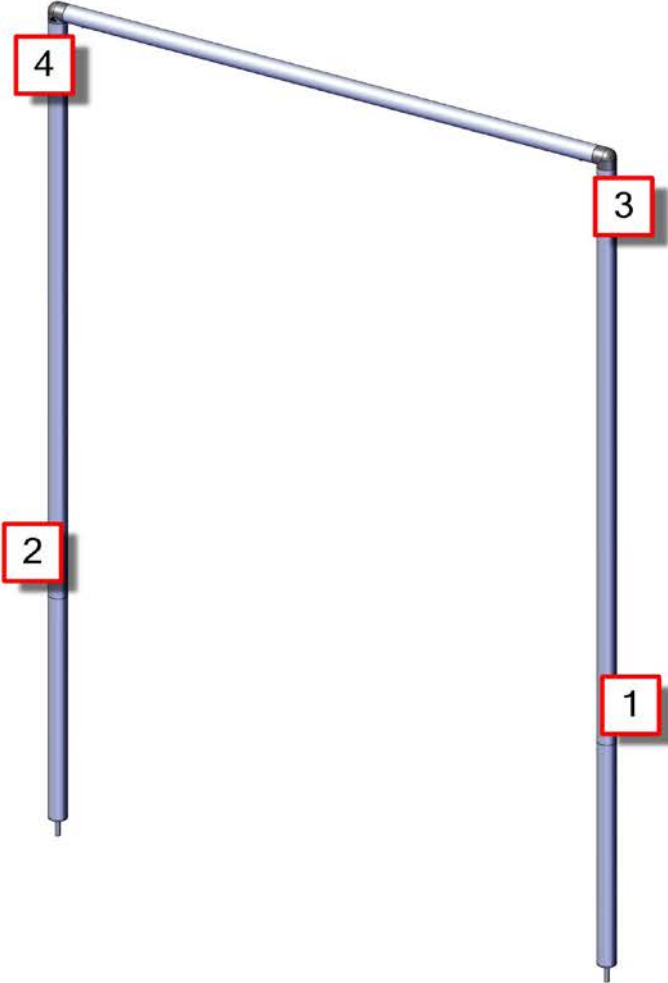

# Kit Assembly

## Step by Step

### Step 1.

Gather the components to build STEP 1. Use the Exploded View and the Labeling Diagram for part labels.

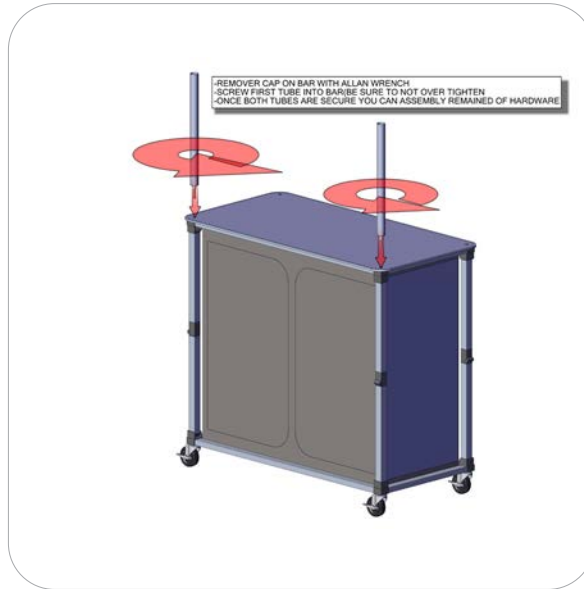

### Step 2.

Gather the components to build STEP 2. Use the Exploded View and the Labeling Diagram for part labels.

Reference Connection Method(s) 1 for more details.



### Step 3.

Gather the components to build STEP 3. Use the Exploded View and the Labeling Diagram for part labels.

Reference Connection Method(s) 1 for more details.

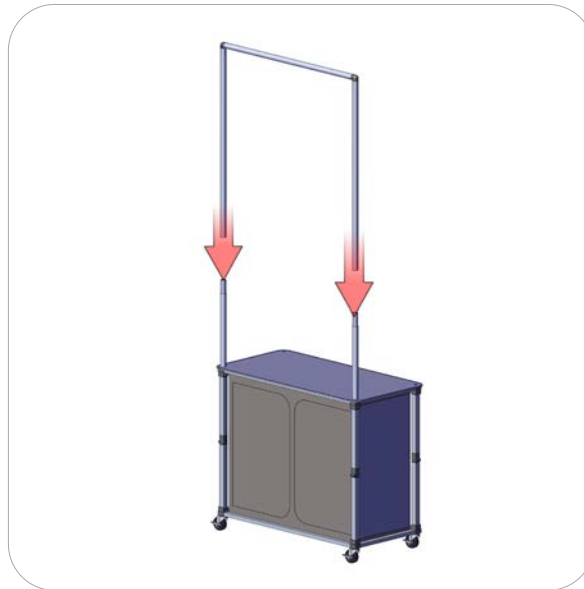

### Step 4.

Setup is complete.

Reference Connection Method(s) 2 for more details.

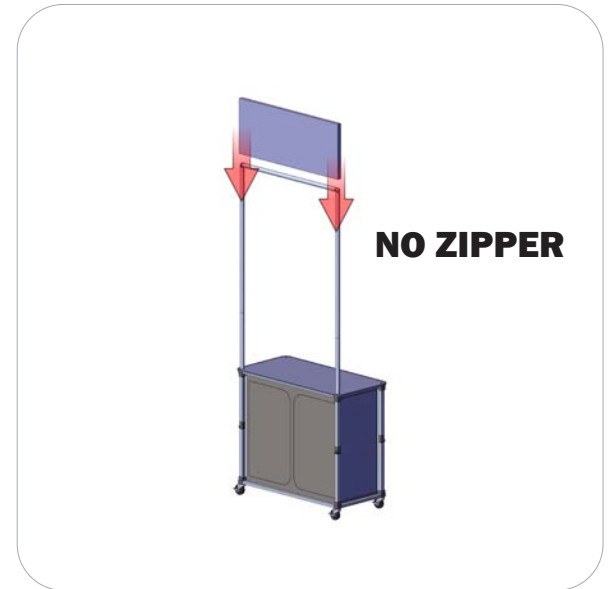



# Connection Methods

Connection Method 1: TC-30-90

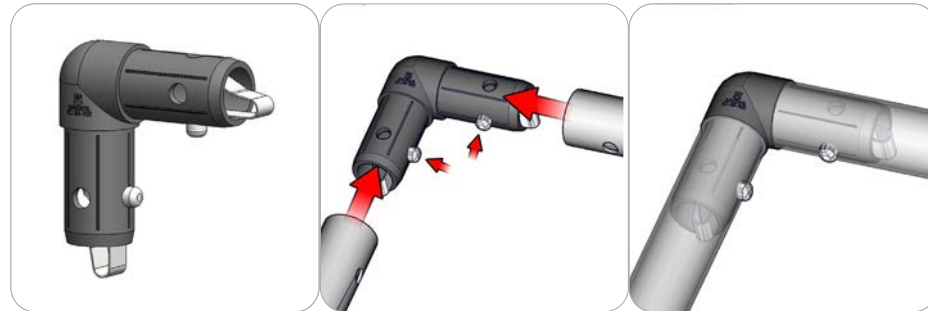

Take the plastic connector and make sure the snap buttons are in proper position for the frame tube holes. Simply press the snap button with your thumb and carefully slide the tube onto the connector. The snap button should pop through. Some twisting may be necessary to assure the snap button has popped all the way through the tube hole. Do not force the connection and be careful with the tube edges, they may be sharp.

Connection Method 2: ATTACH GRAPHIC

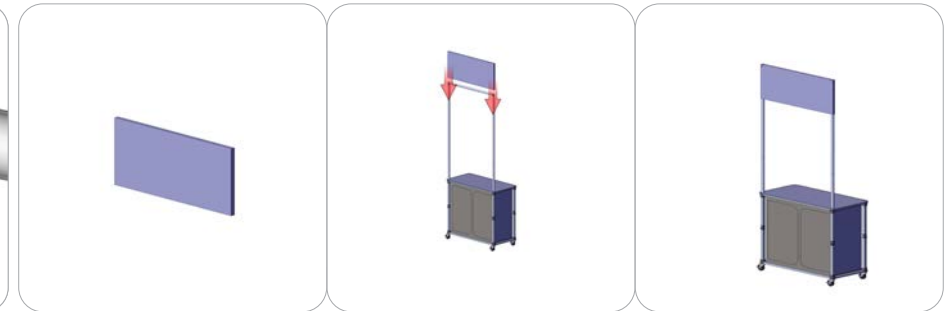

Pull graphic over top of top frame. There is no zipper, graphic just slides over tubes like a pillow top.