

Circle Room Tension Fabric Structure

The Circle Room is a cylinder-shaped space perfect for meetings, graphical displays, projected presentations, a theater setting & much more. The Circle Room is 15 ft in diameter, 8 ft tall and features two 7 ft tall doorways, encouraging traffic flow through the structure.

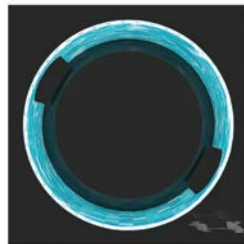
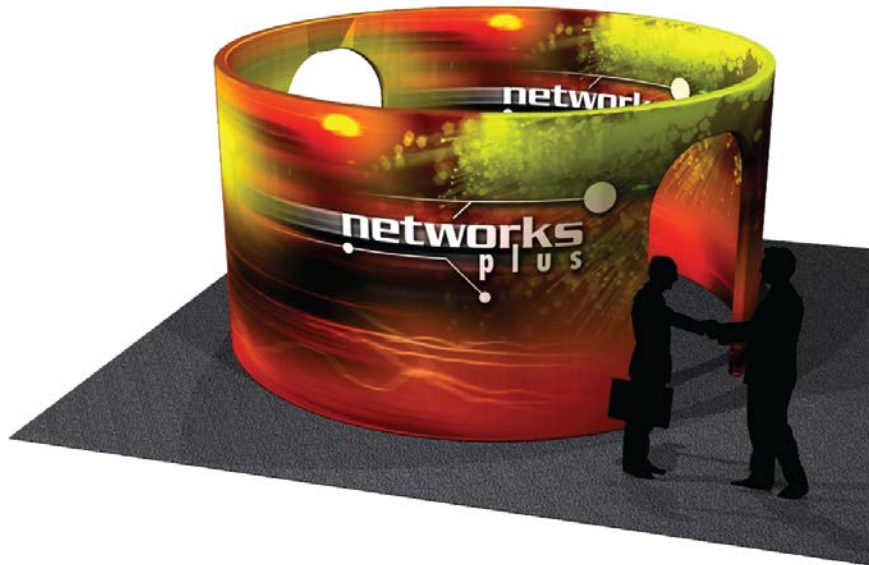

Top View

features and benefits:

- State-of-the-art 50mm curved aluminum tube frame with heavy-duty internal spigots
- Cylinder-shaped room is 15ft in diameter
- Two 7ft tall doorways encourage traffic flow
- Kit includes: one frame, one dye-sublimated zipper pillowcase graphics, and 3 wheeled molded storage cases
- Lifetime hardware warranty against manufacturer defects

dimensions:

Hardware	Graphic
<p>Assembled unit: 180" dia. x 96"h (open on top) 4571 mm(dia) x 2439mm(h)</p> <p>Approximate kit weight (includes graphic): 148.11 lbs / 67 kgs</p>	<p>Total visual area: 564.4"w x 96"h</p> <p>Outside visual area: 564.4"w x 96"h Inside visual area: 552.56"w x 96"h</p> <p>Refer to related graphic template for more information.</p>
<p>Shipping</p> <p>Shipping dimensions - ships in 3 cases: 3 cases: 18"l x 18"w x 40" up to 66"h (per case)</p> <p>Approximate shipping weight (with cases): 229.11 lbs / 110 kgs</p>	<p>Graphic material: Dye-sublimated zipper pillowcase fabric</p> <p>Single-sided treehouse outside printed only</p>



**beautiful
DISPLAYS**

2010 Hancock Street
 San Diego, CA 92110
 800.697.4670
info@beautifuldisplays.com

We are continually improving and modifying our product range and reserve the right to vary the specifications without prior notice. All dimensions and weights quoted are approximate and we accept no responsibility for variance. E&OE. See Graphic Templates for graphic bleed specifications.

Parts Included

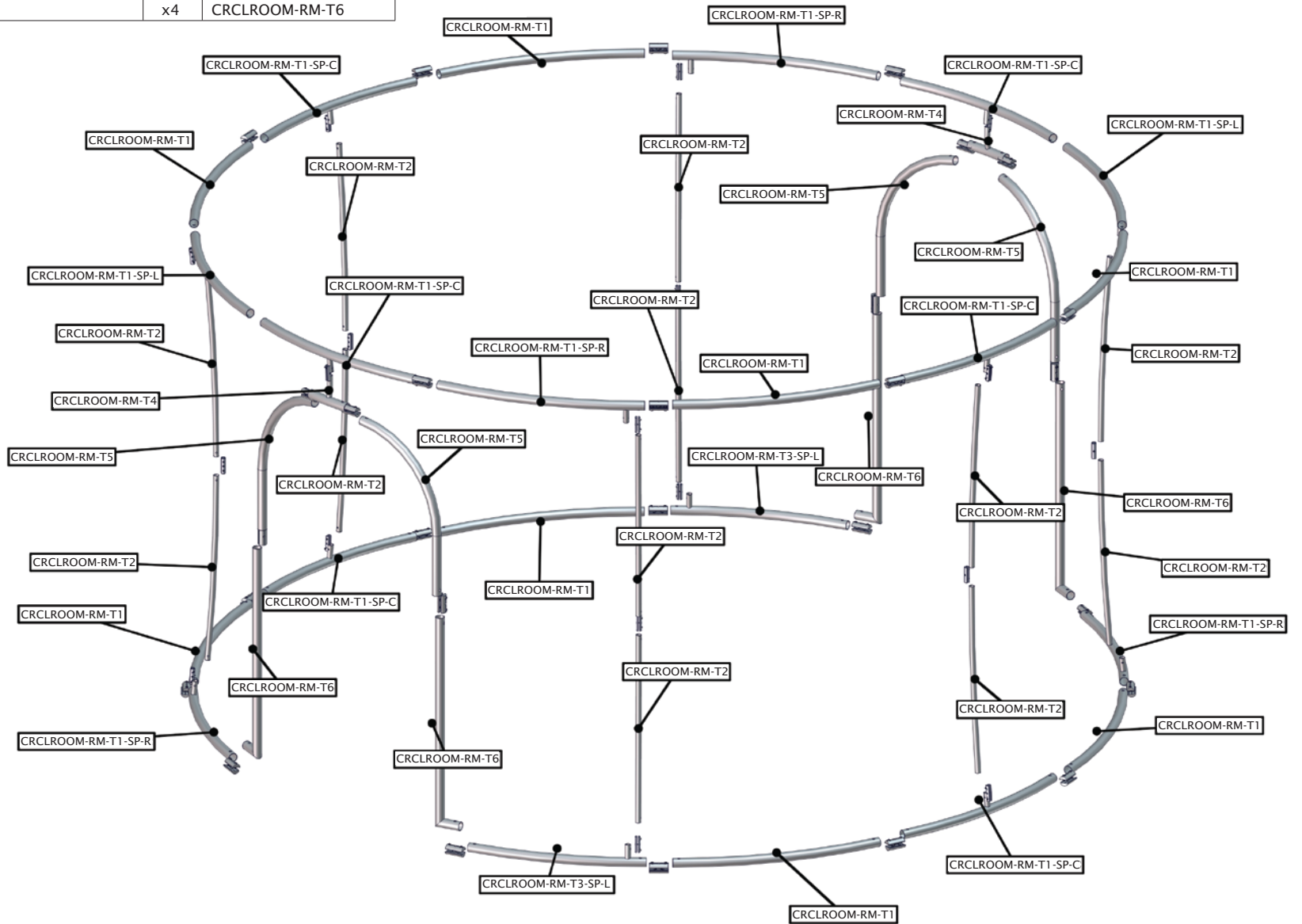
Part Label	Qty	Part Code
50MM CURVED TUBE WITH SPREADER	x10	CRCLROOM-RM-T1-SP
50MM CURVED TUBE WITH SPREADER RIGHT SIDE	x2	CRCLROOM-RM-T3-SP-R
30MM CURVED SPREADER	x12	CRCLROOM-RM-T2
50MM CURVED TUBE	x8	CRCLROOM-RM-T1
50MM CURVED TUBE WITH SPREADER	x1	CRCLROOM-RM-T4
50MM CURVED TUBE WITH SPREADER RIGHT SIDE	x2	CRCLROOM-RM-T1-SP-R
50MM CURVED TUBE WITH SPREADER	x1	CRCLROOM-RM-T4
50MM CURVED TUBE	x4	CRCLROOM-RM-T5
50MM CORNER TUBE	x4	CRCLROOM-RM-T6



ASSEMBLE FRAME AS SHOWN

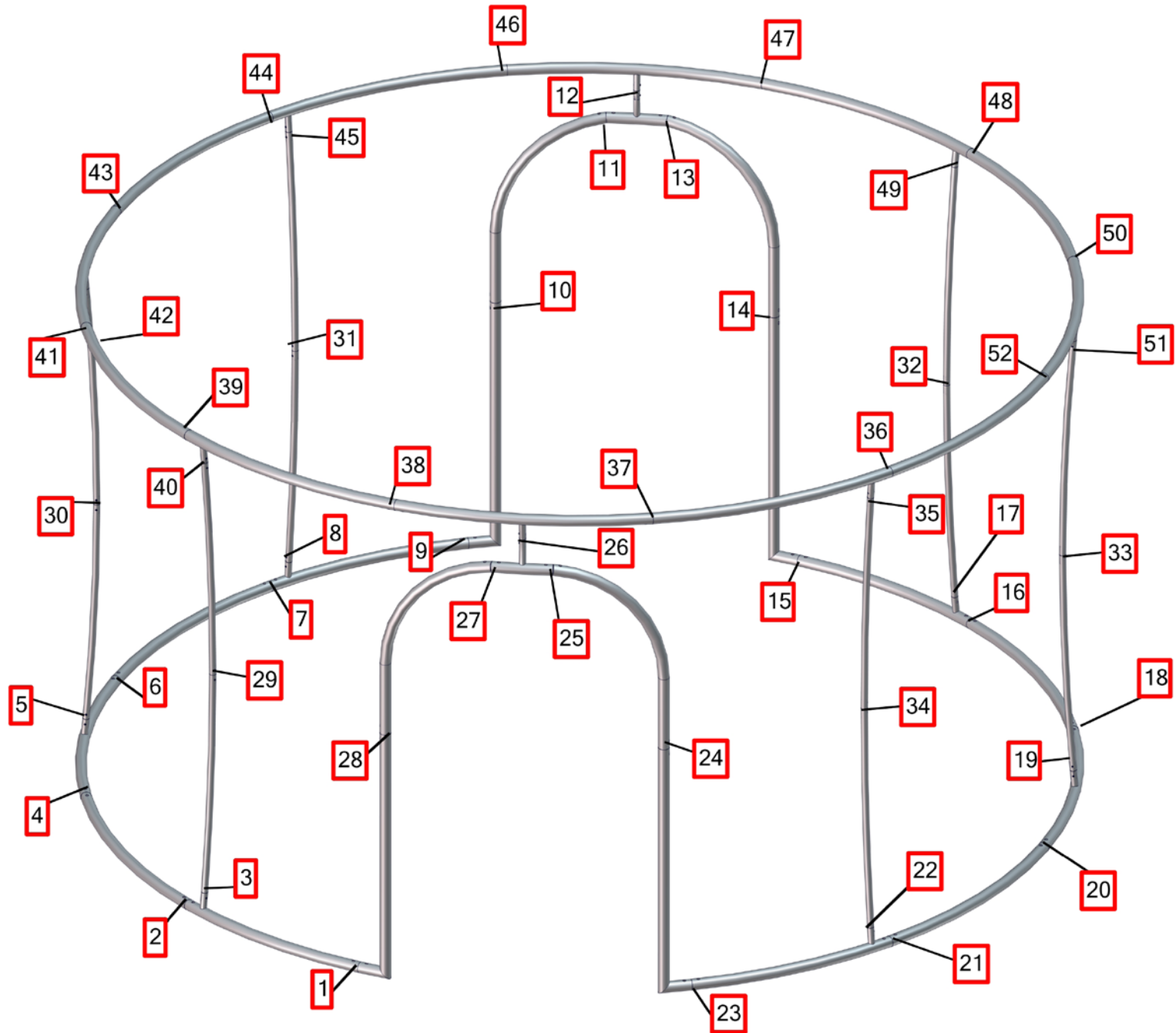

STEP 1: ASSEMBLE FRAME

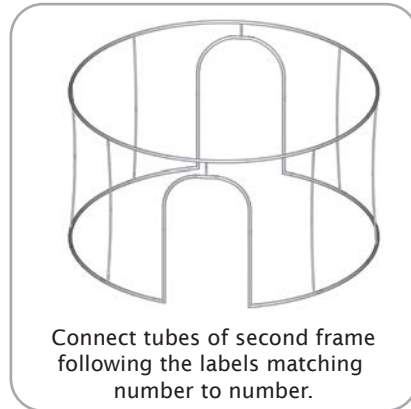
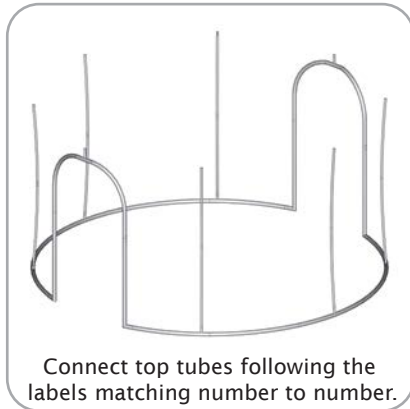
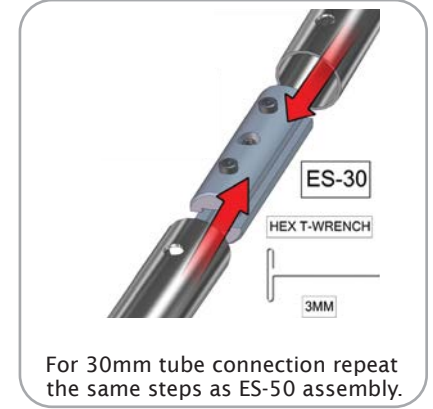
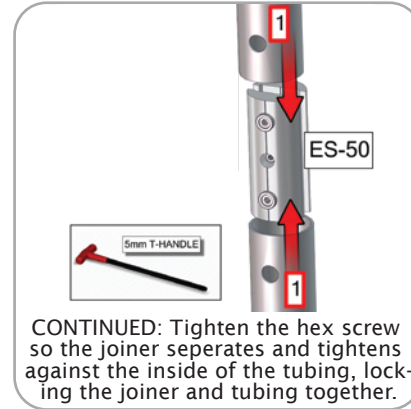
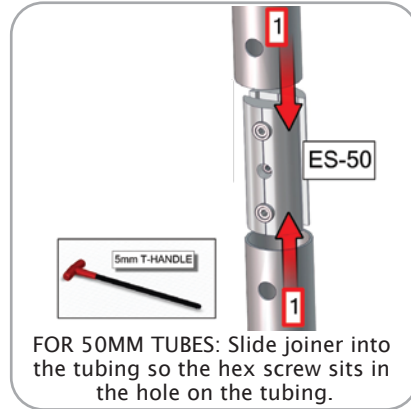
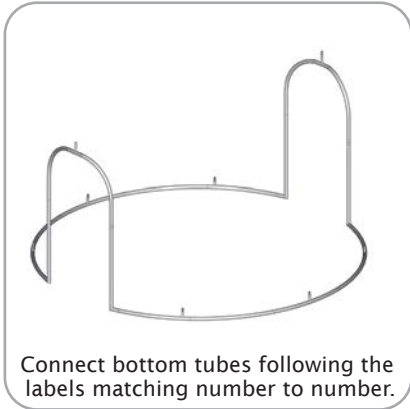

STEP 2: ATTACH GRAPHICS

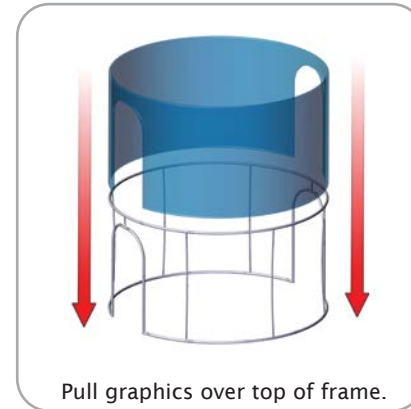

STEP 3: ZIP GRAPHIC

